



Getting started FLIR Cx series

Copyright

© 2014, FLIR Systems, Inc.

All rights reserved worldwide. Names and marks appearing herein are either registered trademarks or trademarks of FLIR Systems and/or its subsidiaries. All other trademarks, trade names or company names referenced herein are used for identification only and are the property of their respective owners.

Document identity

Publ. No.: T559907
Release: AA
Commit: 20775
Head: 20775
Language: en-US
Modified: 2014-11-17
Formatted: 2014-11-17

Corporate Headquarters

FLIR Systems, Inc.
27700 SW Parkway Ave.
Wilsonville, OR 97070
USA
Telephone: +1-503-498-3547

Website

<http://www.flir.com>

Customer support

<http://support.flir.com>

Disclaimer

Specifications subject to change without further notice. Models and accessories subject to regional market considerations. License procedures may apply. Products described herein may be subject to US Export Regulations. Please refer to exportquestions@flir.com with any questions.



T559907

1 Thank you!

Thank you for choosing a camera from FLIR Systems. We hope that the camera will meet your expectations and that you will consider us again for future needs.

The package consists of the following items:

- Infrared camera.
- Battery (inside camera).
- Lanyard.
- Power supply/charger with EU, UK, US, CN, and Australian plugs.
- Printed Getting started guide (this publication).
- USB memory stick with documentation.
- USB cable.

Note

FLIR Systems reserves the right to discontinue models, parts or accessories, and other items, or to change specifications at any time without prior notice.

2 User documentation

Note

Before operating the device, you must read, understand, and follow all instructions, warnings, cautions, and legal disclaimers.

User documentation is available on the USB memory stick.

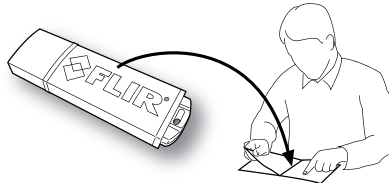

Translated manuals will be placed on <http://support.flir.com> once they become available.

3 FLIR Tools

FLIR Tools lets you quickly create professional inspection reports that clearly show decision-makers what you've found with your infrared camera. Import, analyze, and fine tune images easily. Then incorporate them into concise documents to share findings and justify repairs.

To download FLIR Tools, click the following link:

<http://support.flir.com/tools>

4 Quick Start Guide

4.1 Procedure

Follow this procedure:

1. Charge the battery for approximately 1.5 hours, using the FLIR power supply.
2. Push the On/off button  to turn on the camera.
3. Aim the camera toward your target of interest.
4. Push the Save button to save an image.

(Optional steps)

5. Install FLIR Tools on your computer.
6. Start FLIR Tools.
7. Connect the camera to your computer, using the USB cable.
8. Import the images into FLIR Tools.
9. Create a PDF report in FLIR Tools.

5 Description

5.1 View from the front

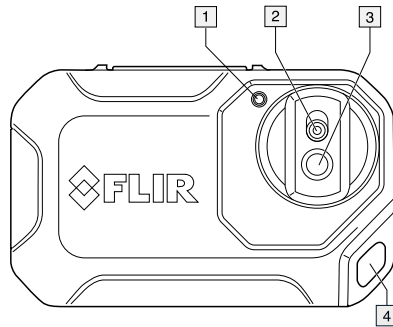

1. Camera lamp.
2. Digital camera lens.
3. Infrared lens.
4. Attachment point.

5.2 View from the rear

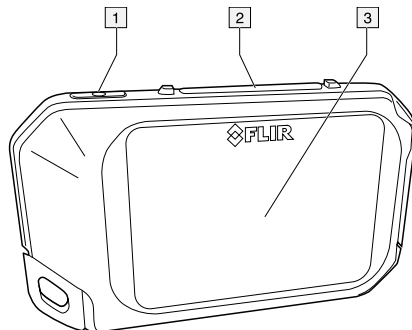

1. On/off button.
2. Save button.
3. Camera screen.

5.3 Connector

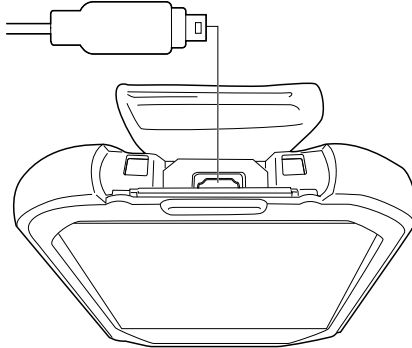

The purpose of this USB Micro-B connector is the following:

- Charging the battery using the FLIR power supply.
- Moving images from the camera to a computer for further analysis in FLIR Tools.

Note

Install FLIR Tools on your computer before you move the images.

5.4 Screen elements

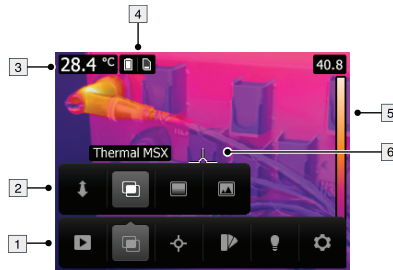

1. Main menu toolbar.
2. Submenu toolbar.
3. Result table.
4. Status icons.
5. Temperature scale.
6. Spotmeter.

5.5 Auto-orientation

The camera has an auto-orientation feature, which means that the camera automatically adjusts the measurement information on the display to the vertical or horizontal position of the camera.

Note

The auto-orientation feature is enabled by a setting. Select *Settings > Device settings > Auto orientation > On*.

5.6 Navigating the menu system

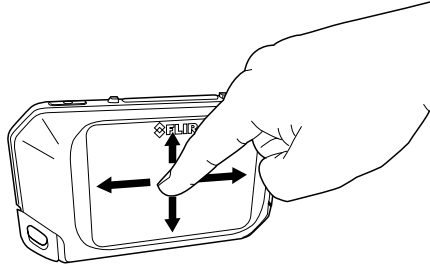

The camera has a touch screen. You can use your index finger or a stylus pen specially designed for capacitive touch usage to navigate the menu system.

Tap the camera screen to bring up the menu system.

6 Customer support

Do not hesitate to contact our Customer Support Center at <http://support.flir.com> if you experience problems or have any questions about your product.



99 Washington Street
Melrose, MA 02176
Phone 781-665-1400
Toll Free 1-800-517-8431

